

# Owner's Manual



PUV-Basic  
PUV-8  
PUV-16

(NSF Standard 55  
Class B Certified)

Congratulations. By purchasing this system, you have taken the first step in ensuring safe drinking water. Designed using the most advanced UV technology available today, your UV system is designed to provide you with years of trouble free operation with minimal maintenance required.



## KEY INFORMATION YOU SHOULD KNOW:

- A 5-micron (nominal) sediment filter must be installed upstream of (before) any UV system.
- This product is for indoor use only. Keep all components clean and dry.
- Clean the sleeve regularly for optimum performance.
- Not for use in salt water applications.

**Date of installation:** \_\_\_\_\_

**Installed by:** \_\_\_\_\_

**Installer phone #:** \_\_\_\_\_

**Serial #:** \_\_\_\_\_

(Found on label on side of Power Supply)

425 Clair Rd. W, Guelph, Ontario, Canada N1L 1R1

t. (+1) 519.763.1032 • tf. 1.800.265.7246 (US and Canada only) • f. (+1) 519.763.5069 • t. +31 73 623 8116 (Europe only)

e-mail: info@viqua.com www.viqua.com



System Tested and Certified by  
NSF International against CSA  
B483.1 and NSF/ANSI 55 for  
Disinfection Performance, Class B

520240-R\_RevB

<b>Potential Hazard</b>	<b>Safety Measures</b>
UV Exposure	<p>Never illuminate UV Lamp outside of the UV Chamber.</p> <p>Never look directly at illuminated UV Lamp, even when using protective gear.</p> <p>Always use protective gear, including gloves and UV safety glasses.</p> <p>If accidental exposure occurs, immediately cool affected area and consult physician.</p>
Electrical Shock	<p>Disconnect power to system before performing any maintenance or repair.</p> <p>There may be more than one source of power.</p>
Impalement	<p>Never perform any physical inspection, repair or maintenance on UV Chamber unless UV chamber has been isolated and depressurized.</p> <p>Never service UV Lamps, Sleeves or associated hardware until depressurization of UV chamber has been confirmed.</p>
Hot chamber	<p>Allow UV Lamps, UV Chamber to cool for a minimum of 10 minutes before handling.</p>
Cut or ingestion	<p>Ensure the quartz sleeve or lamp is not broken, cracked or damaged in any way when handling equipment.</p>
Scald from water	<p>When there is no water flow, the water in the chamber will become hot. To prevent scalding, allow the system to cool before draining the system.</p>
Fire	<p>Do not store any combustible or flammable material close to the system.</p>
Hg Exposure	<p>The UV lamp contains mercury. If the lamp breaks, then avoid inhalation or ingestion of the debris and avoid exposure to eyes and skin. Never use a vacuum cleaner to clean up a broken lamp as this may scatter the spilled mercury. Obey local regulations and guidelines for the removal and disposal of mercury waste.</p>
Water leak	<p>Use proper plumbing materials to avoid potential material degradation from UV exposure.</p>

# SAFETY INSTRUCTIONS

## GROUNDING

This product must be grounded. If it should malfunction or breakdown, grounding provides a path of least resistance for electric current to reduce the risk of electrical shock. This system is equipped with a cord having an equipment-grounding conductor and a grounding plug. The plug must be plugged into an appropriate outlet that is properly installed and grounded in accordance with all local codes and ordinances.

**DANGER** – Improper connection of the equipment-grounding conductor can result in a risk of electrocution. Check with a qualified electrician or service personnel if you are in doubt as to whether the outlet is properly grounded. Do not modify the plug provided with this system – if it will not fit the outlet, have a proper outlet installed by a qualified electrician. Do not use any type of adapter with this system.

## GROUND FAULT CIRCUIT INTERRUPTER PROTECTION

To comply with the National Electrical Code (NFPA 70) and to provide additional protection from the risk of electric shock, this system should only be connected to a properly grounded, grounding-type power supply receptacle that is protected by a Ground Fault Circuit Interrupter (GFCI). Inspect operation of GFCI as per manufacturers suggested maintenance schedule.

## EXTENSION CORDS

If an extension cord is necessary, use only 3-wire extension cords that have 3-prong grounding-type plugs and 3-pole cord connectors that accept the plug from this system. Use only extension cords that are intended for outdoor use. Use only extension cords having an electrical rating not less than the rating of the system. A cord rated for less amperes or watts than this system rating may overheat. Exercise caution when arranging the cord so that it will not be tripped over or pulled. Do not use damaged extension cords. Examine extension cord before using and replace if damaged. Do not abuse extension cord. Keep extension cord away from heat and sharp edges. Always disconnect the extension cord from the receptacle before disconnecting this system from the extension cord. Never yank cord to pull plug from outlet. Always grasp the plug and pull to disconnect.

**WARNING** – Always shut-off water flow and release water pressure before servicing. To guard against injury, basic safety precautions should be observed, including the following:

1. READ AND FOLLOW ALL SAFETY INSTRUCTIONS.
2. **DANGER** – To avoid possible electric shock, special care should be taken since water is employed in the use of this system. Unless a situation is encountered that is explicitly addressed by the provided maintenance and troubleshooting sections, do not attempt repairs yourself; refer to an authorized service facility.
3. **CAUTION** - Do not operate with broken or faulty parts as this may result in exposure to ultraviolet radiation. Contact supplier for replacement parts.
4. Do not operate the system if it has a damaged cord or plug, or if it is malfunctioning or if it has been dropped or damaged in any manner.
5. Always unplug the system, release water pressure before servicing or cleaning. Never yank cord to remove from outlet; grasp the wall plug and pull to disconnect.
6. Do not use the system for other than intended use. The use of attachments not recommended or sold by the manufacturer may cause an unsafe condition.
7. To prevent risk of electrical shock, connect this system only to a properly grounded, grounding-type power supply receptacle that is protected by a Ground Fault Circuit Interrupter (GFCI). Inspect performance of GFCI as per manufacturer's suggested maintenance schedule. If an extension cord is used, ensure it is of a sufficient rating and accepts the plug from this system; never use an adapter.
8. Visually inspect this system prior to installation. If the quartz sleeve or lamp is broken, cracked or damaged in any way, do not use. Contact the supplier for replacement parts.
9. Keep all connections dry and off the ground. Do not touch plug with wet hands.
10. The light emitted by the lamp will cause serious eye damage and burn unprotected skin. Do not plug system into an electrical outlet without first properly securing the lamp into the chamber. Unplug the system prior to removing the lamp from the chamber.
11. If the UV system malfunctions or fails, water must be boiled prior to consumption until the UV system is operational and the water lines have been shocked. System failure is indicated by the system's audible and visual alarms or the absence of any indicator light.
12. Intended for indoor use only. System must not be exposed to weather elements. In seasonal applications, chamber must be drained to prevent freezing.
13. Installation of this system must be in accordance with local plumbing and electrical codes as well as any and all applicable regulations and laws.
14. The UV system is not to be used or played with by children. Persons with reduced physical, sensory or mental capabilities, or lack of experience and knowledge, are also not to handle the UV system unless they have been given supervision or instruction.
15. SAVE THESE INSTRUCTIONS.



**WARNING** – To prevent risk of electrical shock, connect this system only to a properly grounded, grounding-type power supply receptacle that is protected by a Ground Fault Circuit Interrupter. Pull plug before servicing or replacing lamp. Keep all connections dry and off the ground. Do not touch plug with wet hands.



**WARNING** – Do not look directly at UV lamp when it is operating. The light emitted by the lamp will cause serious eye damage and burn unprotected skin.



**WARNING** – Read manual before installing or servicing this system. Only authorized personnel possessing a strong understanding of this system should attempt to replace lamp or service this system.



**WARNING** – Always shut-off water flow and release water pressure before servicing.

**NOTE** – Maximum pressure rating is 125 PSI (8.62 bar)

**TABLE OF CONTENTS**

Overview	3
What model do I have?	3
Specifications	4
Components	5
Dimensions and layout	7
Installation	9
Installing the UV system	9
Disinfecting the water lines	11
Operation	14
Control panel	14
Troubleshooting	15
Maintenance	16
Sleeve cleaning and lamp replacement	17
Warranty	20

# WHAT MODEL DO I HAVE?

To find out what model you have, look at the label on the side of the power supply.



Model PUV-Basic, Class B certified

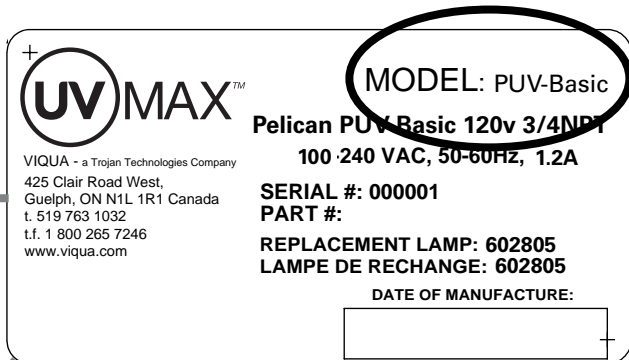

Example label of model PUV-Basic





Model PUV-8 and PUV-16

	PUV-Basic	PUV-8	PUV-16
No-tools maintenance	Yes	Yes	Yes
Safety cap & special lamp plug	Yes	Yes	Yes
Lamp operation indicator	Yes	Yes	Yes
Power supply operation indicator	Yes	Yes	Yes
Reference card	Yes	Yes	Yes
Lamp timer display	--	Yes	Yes
Lamp timer reset button	--	Yes	Yes
Mute button	--	Yes	Yes
Solenoid valve	--	Optional	Optional
External control relay	--	Optional	Optional

# SPECIFICATIONS

## General (All Models)

### Operating Parameters

Maximum operating pressure	125 PSI (862 kPa)
Minimum operating pressure	4 PSI (27.5 kPa)
Maximum ambient air temperature	122 °F (50°C)
Minimum ambient air temperature	32°F (0°C)
Maximum humidity	100%
Maximum hardness	120 ppm (7 grains per gallon)
Maximum iron	0.3 ppm
Minimum UVT	70%
Installation	Vertical or horizontal*
Flow Restrictor	Yes
NSF Certification	NSF Standard 55 Class B 
Rated service life of lamp	1 year
Certification (other)	 

### PUV-Basic

### PUV-8

### PUV-16

### Flow Rates

Rated flow for NSF Std 55, Class B	8.9 gpm (33.7 lpm)	8.9 gpm (33.7 lpm)	15.8 gpm (59.8 lpm)
---------------------------------------	-----------------------	-----------------------	------------------------

### Electrical

Voltage	100-240V AC	100-240V AC	100-240V AC
Frequency	50-60 Hz	50-60 Hz	50-60 Hz
Max. current	0.5 Amp	0.5 Amp	0.85 Amp
Max. power consumption	50 Watts	50 Watts	83 Watts
Lamp power	40 Watts	40 Watts	70 Watts

### Other

UV Chamber Material	304 SST	304 SST	316 SST
Inlet/Outlet	3/4" NPT	3/4" NPT	1" NPT

# COMPONENTS

For replacement components please contact your installer or contact VIQUA directly for a referral: 1 800 265 7246 (North America), 519 763 1032, or info@viqua.com.

## Components - PUV-Basic, PUV-8, PUV-16



Part		Part Number
1	Power supply mounting bracket	All --
2	Reference card	All 603069
3	Power supply (includes Power supply mounting bracket, Reference card, Safety cap, Lamp cord)	PUV-Basic 650713-006 PUV-8, PUV-16 650713-007
4	Power cord	All 602636 (120V) 602637 (230V)
5	Junction box (optional)	PUV-8, PUV-16 650705
6	Safety cap	All 603000
7	Lamp cord	All --

### Components - All Models

Part	Model	Part Number
7 Lamp (includes O-rings)	PUV-Basic, PUV-8, PUV-16	602805 602806
8 O-ring	All	--
9 Sleeve bolt	All	602665
10 Sleeve (includes O-rings)	PUV-Basic, PUV-8, PUV-16	602732 602733
11 UV Chamber (includes Chamber clamp(s), and Ring clamp*)	All	--
12 Ring clamp	All	--
13 Chamber clamp(s)	All	--
14 Solenoid valve kit (optional) (includes Junction Box)	PUV-8 (3/4"), PUV-16	650717-001 650717-002
15 CoolTouch valve (optional)	PUV-8, PUV-16	650537
16 Flow Restrictor	PUV-Basic, PUV-8, PUV-16	440267-R 440268-R

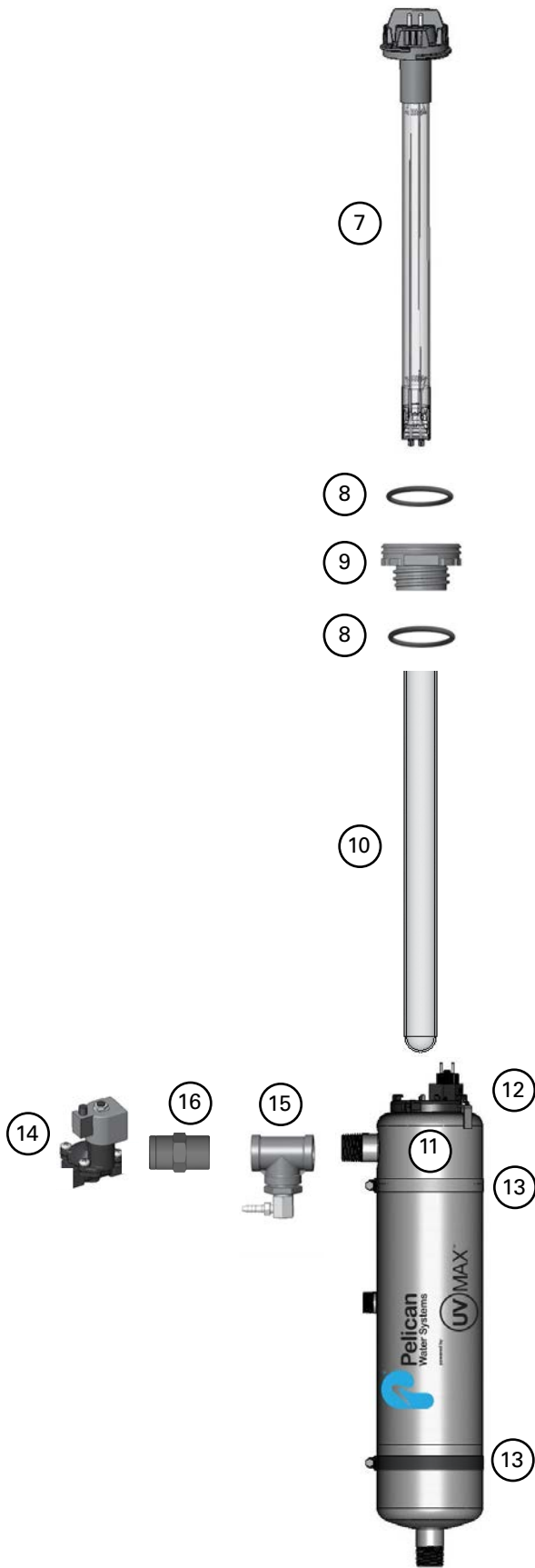



# DIMENSIONS AND LAYOUT

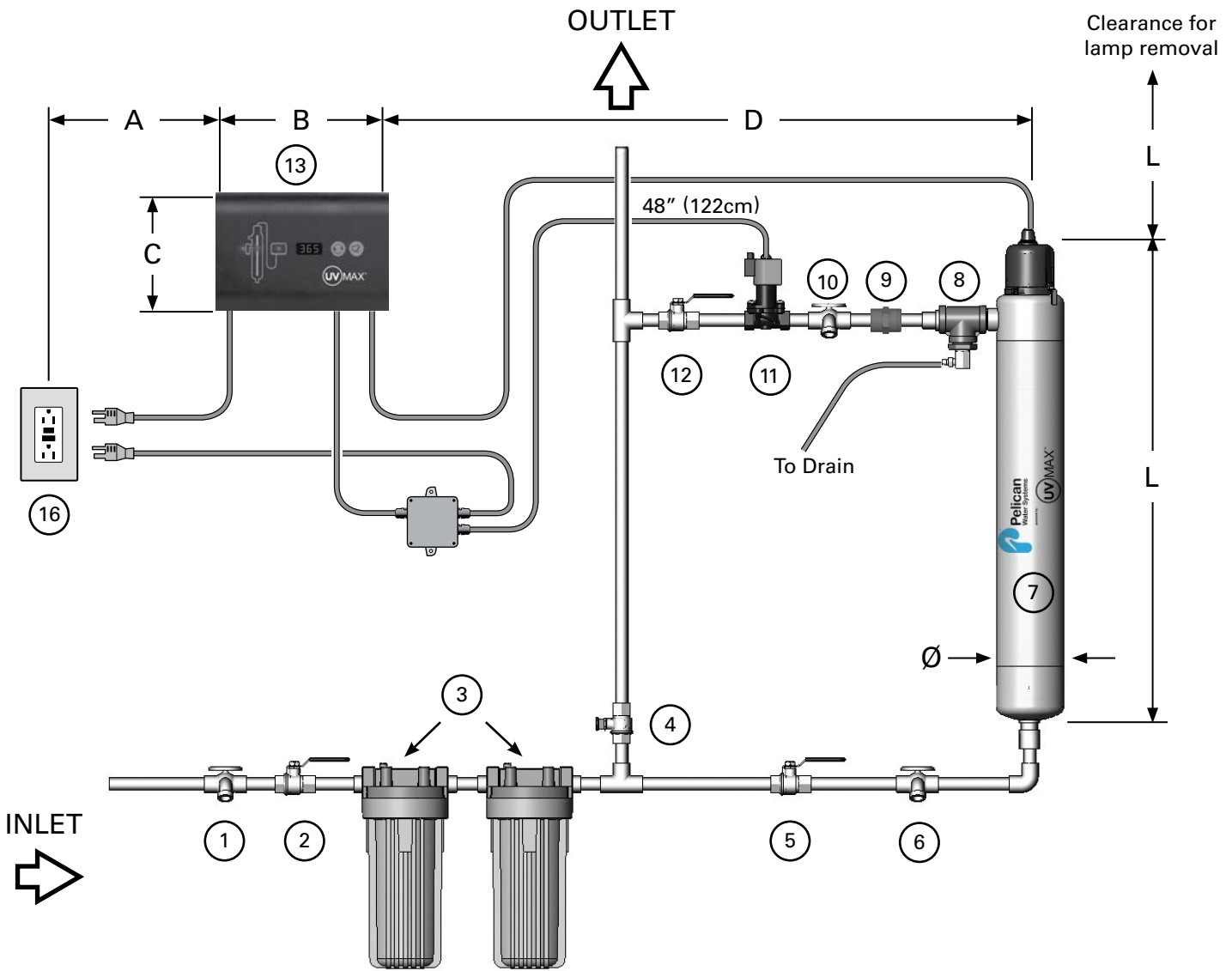

Model	L	Ø	A (max.)	B	C	D (max.)
PUV-Basic	20.5" (52cm)	4" (10cm)	72" (183cm)	8.5" (22cm)	6" (15cm)	54" (137cm)
PUV-8	20.5" (52 cm)	4" (10cm)	72" (183cm)	8.5" (22cm)	6" (15cm)	54" (137cm)
PUV-16	30" (76cm)	4" (10cm)	72" (183cm)	8.5" (22cm)	6" (15cm)	54" (137cm)

OVERVIEW

INSTALLATION

OPERATION

MAINTENANCE

WARRANTY

- 1 Sample valve: Allows for sampling of raw water.
- 2 Shut-off valve: Required to allow maintenance of pre-treatment equipment.
- 3 Pre-treatment (illustrative only): For the UV system to operate effectively, the water should meet certain water quality parameters, as outlined below. To meet these, pre-treatment of the water may be required. Pre-treatment equipment must be installed BEFORE the UV chamber. Pre-treatment systems can be comprised of one or more of the following elements: sediment filters; carbon filters; iron removal systems; water softeners; cyst reduction filters, etc.

**Water Quality Requirements:**

Iron:	< .3 PPM (.3 mg/L)
Hardness:	< 120 PPM (7 Grains Per Gallon)
% UVT:	> 75%
Tannins:	< 0.1 PPM

**IMPORTANT:**  
**A 5 micron (nominal) sediment filter must be installed  
before the UV system and after any water softening equipment**

- 4 Bypass shut-off valve: Bypass line and valve are optional. Intended to provide emergency water supply in the event that the UV system is unavailable.
- 5 Shut-off valve: Required to allow maintenance of UV system.
- 6 Sample valve: Allows for sampling of water entering UV chamber; necessary in order to confirm water being treated is of adequate quality.
- 7 UV chamber: Provides disinfection of the water. Must install Plus model chambers vertically.
- 8 CoolTouch™ valve: Drains water from the chamber that's been warmed by the lamp during periods of no flow.
- 9 Flow Restrictor: Restricts water from flowing over the maximum NSF certified flow rate ensuring an adequate UV dose is maintained.
- 10 Sample valve: Allows for sampling of water immediately following UV treatment; necessary in order to confirm proper operation of UV system.
- 11 Solenoid valve: Optional piece of equipment supplied by VIQUA for PUV-8 and PUV-16 models. Must be used with a junction box. Allows water supply to be shut-off when proper purification cannot be assured.

Note: If the ground from your electrical panel is tied to your copper water lines, and you are using a solenoid valve, installation of an approved ground strap is required. This ground strap will maintain continuity between the lines that have been cut to install the solenoid. Check your local electrical code for the correct clamp and cable size.



- 12 Shut-off valve: Required to allow maintenance of UV system.
- 13 Junction box: An optional piece of equipment for PUV-8 and PUV-16 models. Powers solenoid valves, remote alarms and auto-dialers.
- 14 Power supply: Powers and controls the UV lamp and other devices. Provides human interface, displaying information and allowing control inputs (such as muting the audible alarm).
- 15 Power source: Provides power to the power supply. For safety reasons the outlet must be protected by a Ground Fault Circuit Interrupter (GFCI). NOTE: to protect the power supply, a UL1449 certified (or equivalent) transient voltage surge suppressor is required.

## INSTALLING THE UV SYSTEM

- 1 Determine appropriate **indoor** location of the power supply and chamber, referring to Dimensions and Layout drawing. Power supply should be installed higher than chamber away from all water sources. Ensure adequate clearance above chamber to allow for removal of the lamp and sleeve.

- 2 Screw chamber clamp(s) to the wall (#10 screws recommended.)



- 3 Insert chamber and tighten clamp(s).



- 4 Make all necessary plumbing connections referring to Dimensions and Layout drawing.

Safety cap, lamp plug and power supply figures will look slightly different than those on your system.

- 5 Install power supply mounting bracket to wall using four #8 screws (not provided).



- 6 Slide power supply onto mounting bracket.



- 7 Slide Reference card behind power supply.



- 8



- 9 Insert Lamp/sleeve assembly and screw into chamber.

Caution: Over tightening will break the sleeve.

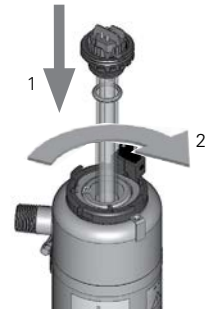

- 10 Align connections by rotating ring clamp (if equipped) to push lamp plug onto end of lamp.

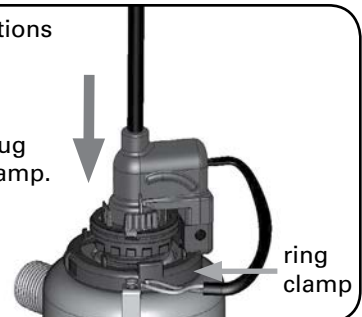

11

Attach ground (green/yellow) and strain relief (red) wires from the lamp plug to the ground lug on the chamber. Secure both wires with locking screw provided.

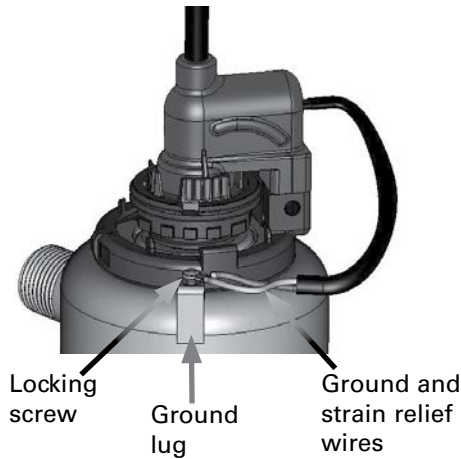

14



Outlet must be protected by a Ground Fault Circuit Interrupter (GFCI).

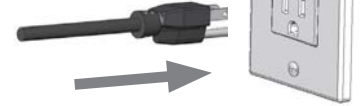

15

Let water flow to one faucet or other water outlet, then close the outlet and check for leaks.

Proceed to Disinfecting The Water Lines.

12

Push safety cap into place.



13

Flow direction must be the same as arrows on the flow restrictor

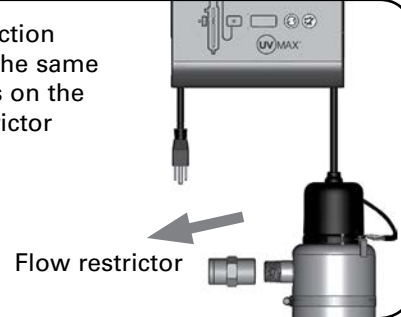

## DISINFECTING THE WATER LINES

UV systems disinfect the water using ultraviolet light, treating the water as it passes through the system. When there is a risk that water downstream of the UV system has been contaminated, it is critical that these water lines be chemically disinfected. Disinfection of the water lines is therefore required after initial system installation and following any period of time during which the system is inoperative, whether due to an alarm condition, a power failure, or for any other reason. Make sure the UV system is on during the entire disinfecting process.

1

Make sure power supply is plugged in for entire disinfection process.

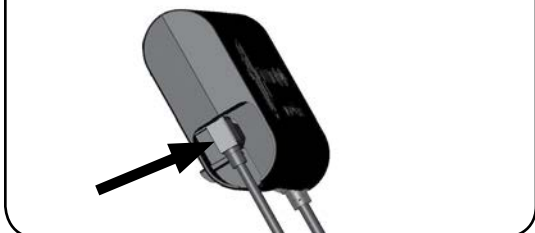

2

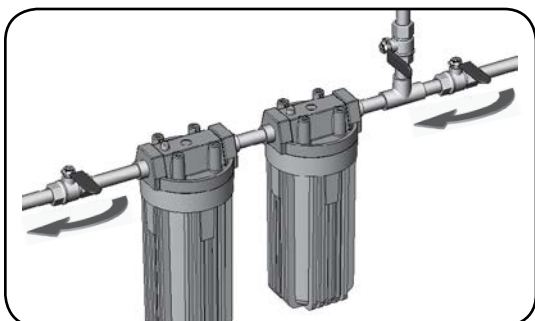

3

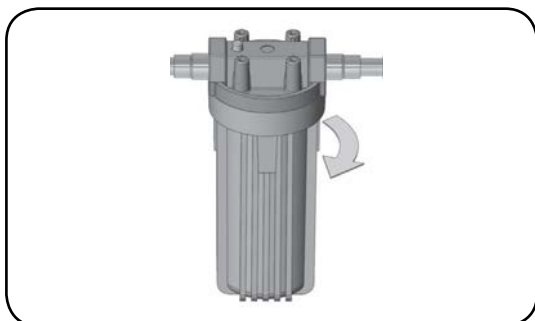

4



5

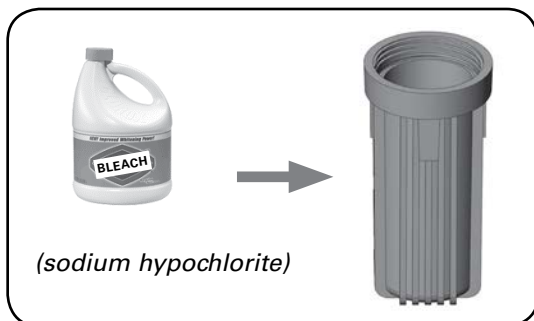

6

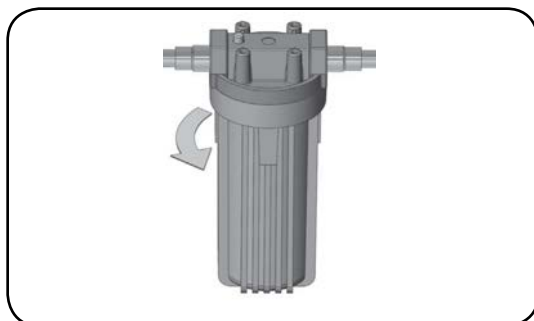

7

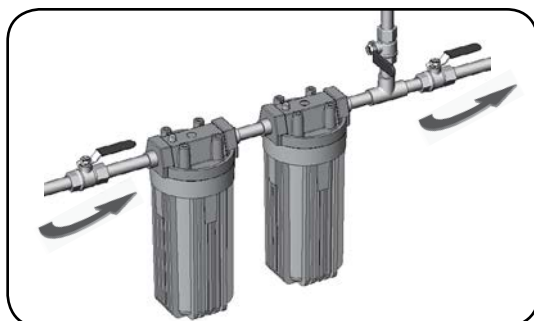

8

Allow water to fill UV chamber.

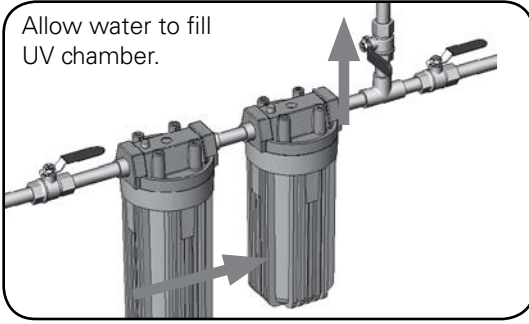

9

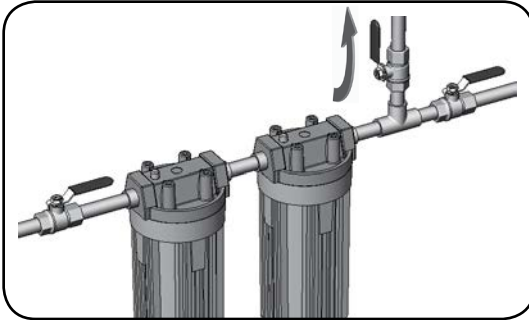

10

Go to a water outlet and allow the cold water to flow until you can smell bleach, then stop the flow. Allow hot water (if present) to flow until you can smell bleach, then stop the flow. Repeat procedure at all water outlets. Remember to include all faucets, washing machines, toilets, outside taps, and other water outlets. **Note:** You will likely run out of bleach; if you cannot smell bleach at a given outlet, turn off the main water supply, depressurize and add more bleach to the filter housing.



11

Let the bleach sit in the water lines for at least four hours.



12

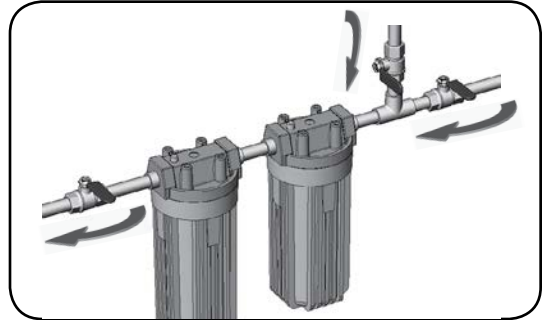

13

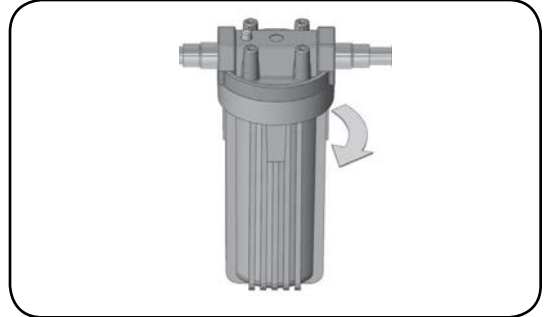

14

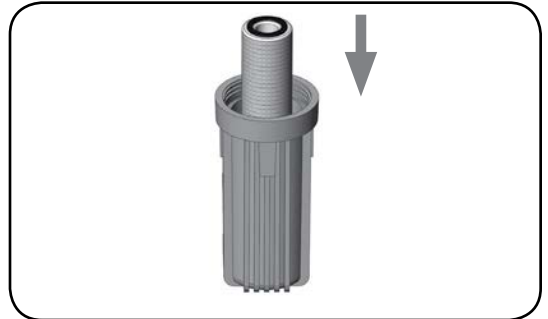

15

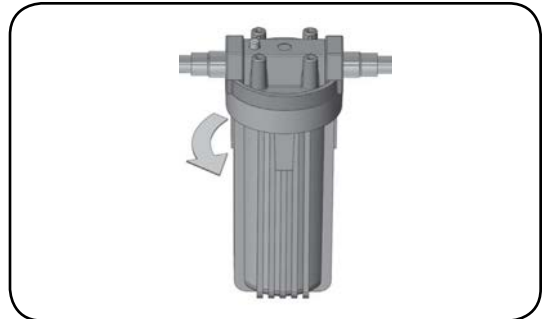

16

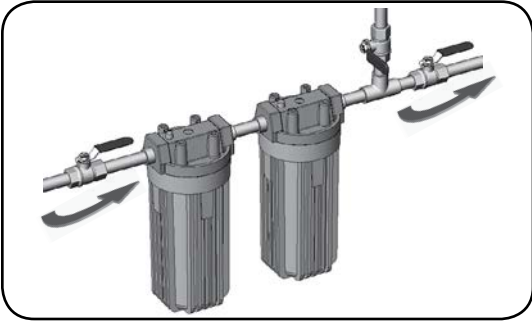

17

Flush all water outlets until bleach can no longer be smelled (at least 5 minutes).



20



21

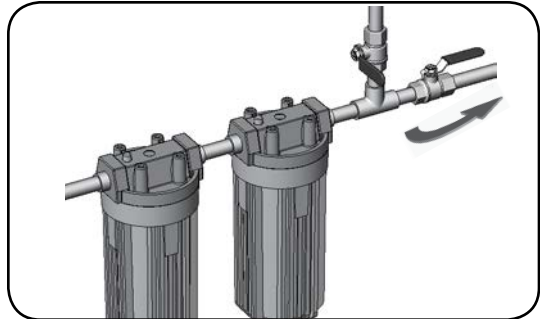

18

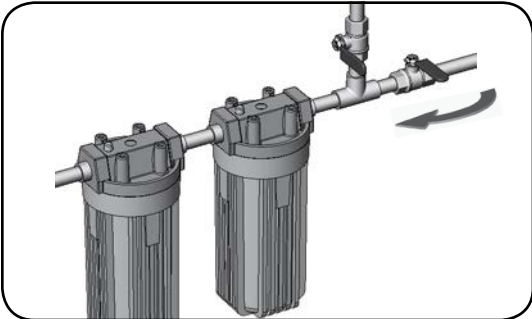

19



## CONTROL PANEL



### Buttons and Display

For all models.

<b>A</b>	Lamp timer display	Counts down from 365 days to show time for annual lamp replacement.
<b>B</b>	Lamp timer reset	After installing a new lamp, press and hold for five seconds to reset Lamp timer to 365.
<b>C</b>	Mute	Press to silence audible alarm. When the alarm is due to the lamp's age, the mute button will silence the audible alarm for 7 days; this may be repeated up to a maximum of 4 times. After that, the button will silence for only 24 hours. When the alarm is due to any other issue, the mute button will silence the audible alarm for 24 hours.

### Indicator lights

Indicator lights only indicate a problem with the component when flashing red.

	Green	Yellow*	Flashing red	Solid red
<b>1</b>	Lamp operating normally	Warning; lamp will require replacement shortly	Lamp disconnected; unplug system, reconnect lamp and plug-in system again Lamp failure; replace lamp	Lamp inactive due to power supply failure
<b>2</b>	Power supply operating normally	Air temperature around system is too warm	Power supply failure; replace power supply	Power supply inactive due to lamp failure

\* Yellow indicator lights are a function of PUV-8 and PUV-16 models only.



## TROUBLESHOOTING

The table below is a list of *possible* causes and solutions. Before replacing parts, please contact VIQUA Technical Assistance for any new troubleshooting techniques : 1-800-265-7246

Symptom	Possible cause	Possible solution
No power	GFCI and/or breaker tripped	Reset GFCI and/or breaker
	Transient voltage surge suppressor (TVSS) damaged	Replace TVSS
	Power supply damaged	Replace power supply and use a TVSS
GFCI or breaker repeatedly trips	Connection between lamp and lamp plug is wet	Clean and dry lamp pins and lamp plug, check unit for leaks or condensation
	Short-circuit in the electrical assembly	Replace power supply
Leak at inlet or outlet	Threaded pipe fittings are leaking	Clean threads, reseal with Teflon tape and retighten
Leak detected from area of UV chamber	Condensation of moist air on cold chamber (slow accumulation)	Control humidity or relocate unit
	O-ring damaged, deteriorated or incorrectly installed	Inspect and replace if deteriorated
	Lamp/sleeve assembly not properly installed (too tight or not tight enough)	Tighten assembly hand-tight
Alarm	See Control Panel section	See Control Panel section
System is operating but water tests reveal bacterial contamination	Equipment downstream of UV system is acting as a breeding ground for pathogens	Ensure UV is the last piece of treatment equipment
	Pathogens are residing in the distribution lines post-UV	Ensure all distribution lines have been disinfected with chlorine - see Disinfecting the Water Lines section
	Recontamination from pipe dead-ends	Remove any pipe dead-ends and flush with chlorine - see Disinfecting the Water Lines section
Lamp timer does not read anything	Unit is unplugged	Plug unit into AC power outlet
	No power at AC power outlet	Replace fuse or reset breaker
	Power cord is damaged	Replace power cord
	Power surge caused damage to electrical assembly	Replace power supply and use a surge protector

## SLEEVE CLEANING & LAMP REPLACEMENT

### Sleeve cleaning

Minerals in the water slowly form a coating on the sleeve. This coating must be removed because it reduces the amount of UV light reaching the water, thereby reducing purification performance.

*Basic models:* please clean the sleeve regularly (3-4 times per year, or more often depending on water quality).

When only cleaning is required, follow instructions and re-install the current lamp.

### Lamp replacement

The amount of UV light created by the lamp decreases over time, requiring that the lamp be replaced every 12 months. **NOTE:** The UV system is designed to operate continuously and should not be shut off for short periods of time, such as over a period of less than three weeks.

*PUV-Basic Model:* Please keep track of your lamp's life. After 12 months follow these instructions to replace system with a new lamp.

*PUV-8 and PUV-16 Models :* The system will automatically notify you after 12 months to replace the lamp. Follow these instructions.

### Equipment required:



Clean cotton, latex or plastic gloves are preferred.



Scale remover such as vinegar or a citrus-based product.



Cloth must be soft, lint-free, and chemical-free. No clean-wipes.



Cotton swab.  
(For Plus models only)

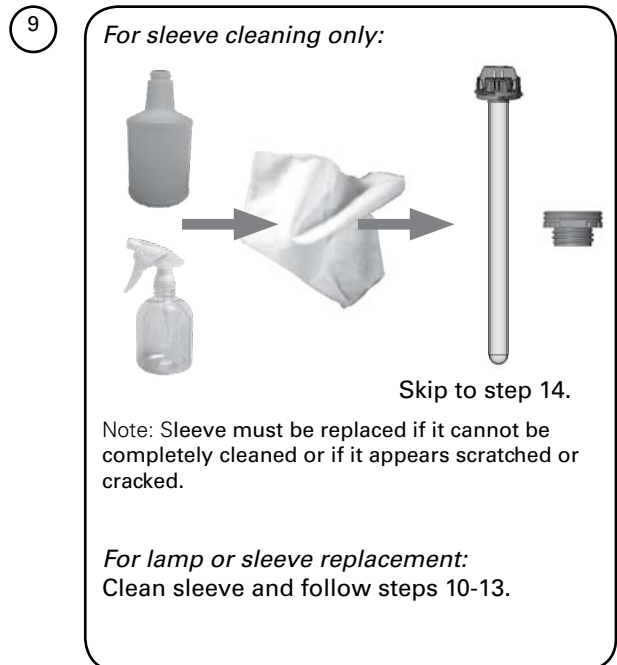
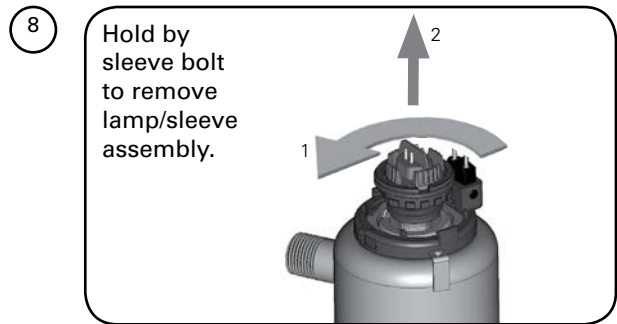
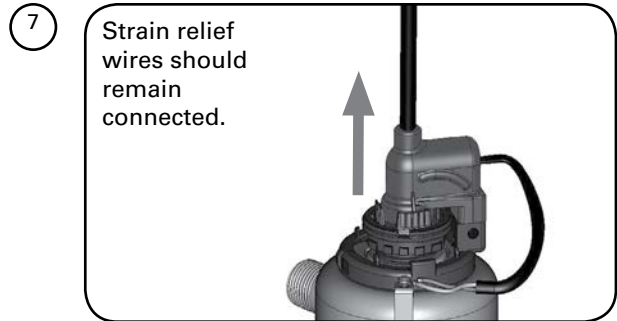
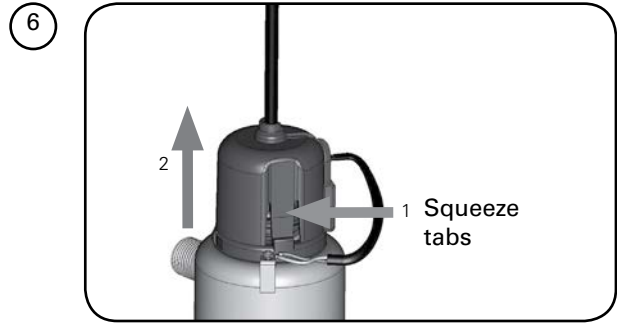
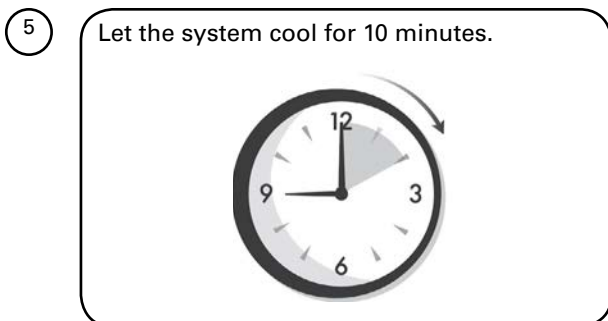
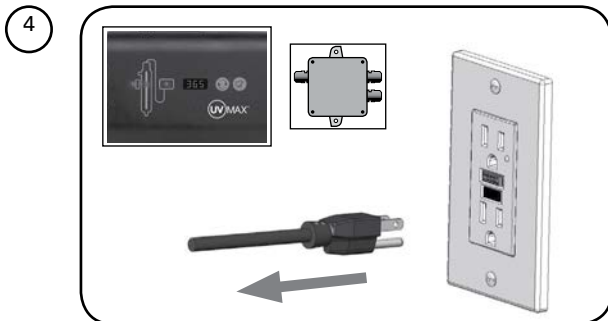
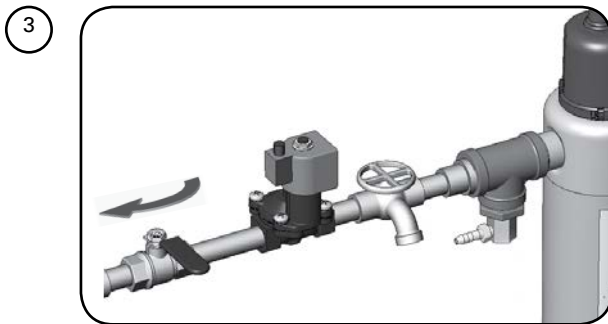
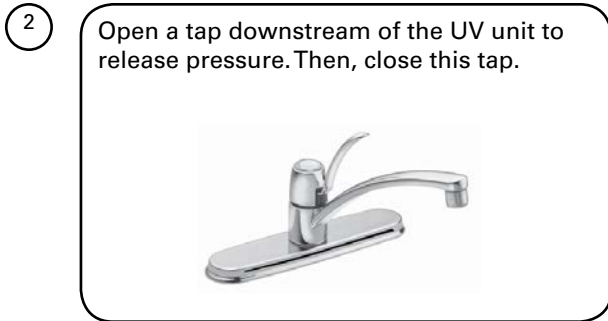
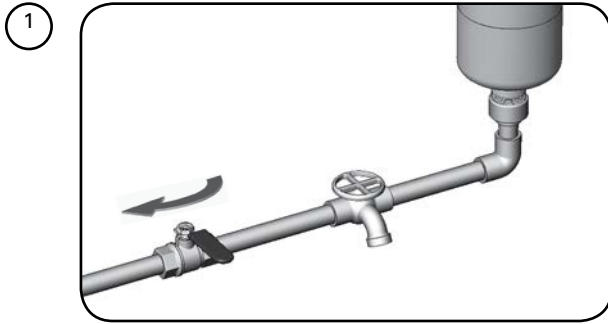

10

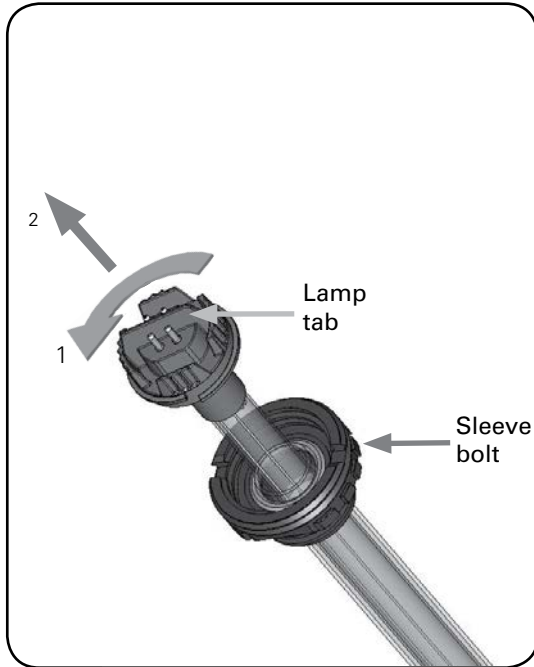

13



11

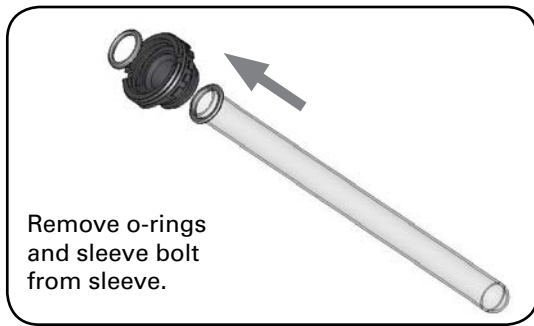

14

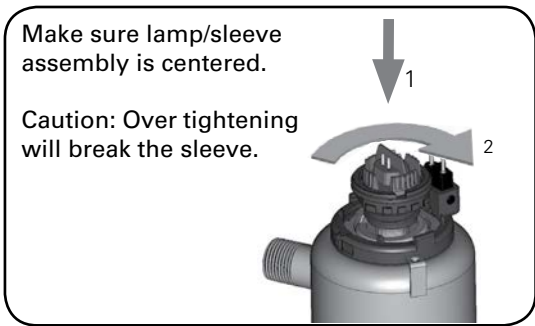

12



15

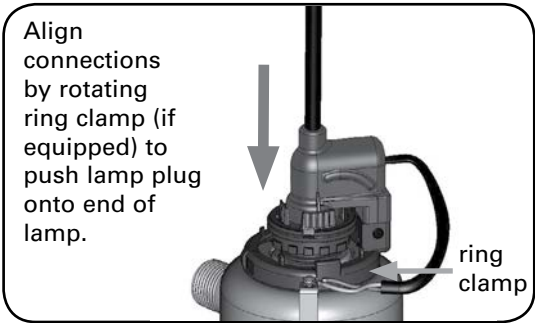

16

Push safety cap into place.



17

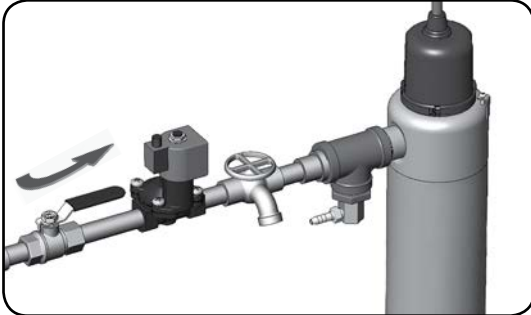

18

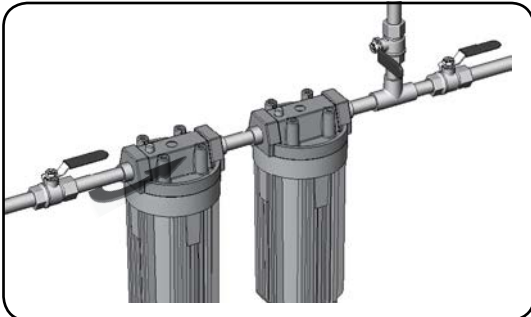

19

Check for leaks.

20

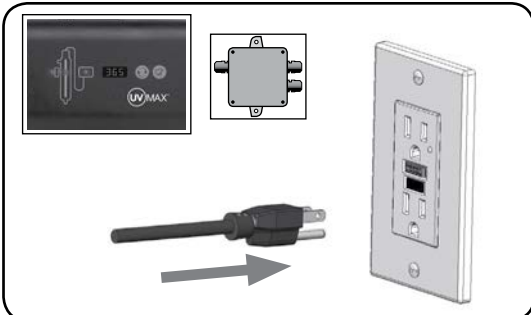

21

If lamp was replaced and you have a PUV-8 and PUV-16 model: Press and hold Lamp timer reset button for 5 seconds. Display should read 365.

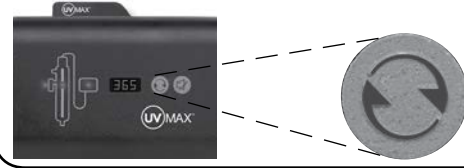

22

Disinfect the water lines. Refer to Disinfecting the Water Lines in Installation section.

# WARRANTY

## Our Commitment

VIQUA is committed to ensuring your experience with our products and organization exceeds your expectations. We have manufactured your UV purification system to the highest quality standards and value you as our customer. Should you need any support, or have questions about your system, please contact our Technical Support team at 1.800.265.7246 or [technicalsupport@viqua.com](mailto:technicalsupport@viqua.com) and we will be happy to assist you. We sincerely hope you enjoy the benefits of clean, safe drinking water after the installation of your UVMAX® purification system.

## How to Make a Warranty Claim

NOTE: To maximise the disinfection performance and reliability of your UVMAX® product, the system must be properly sized, installed and maintained. Guidance on the necessary water quality parameters and maintenance requirements can be found in your Owner's Manual.

In the event that repair or replacement of parts covered by this warranty are required, the process will be handled by your dealer. If you are unsure whether an equipment problem or failure is covered by warranty, contact our Technical Support team at 1.800.265.7246 or e-mail [technicalsupport@viqua.com](mailto:technicalsupport@viqua.com). Our fully trained technicians will help you troubleshoot the problem and identify a solution. Please have available the model number (system type), the date of purchase, the name of the dealer from whom you purchased your UVMAX® product ("the source dealer"), as well as a description of the problem you are experiencing.

To establish proof of purchase when making a warranty claim, you will either need your original invoice, or have previously completed and returned your product registration card via mail or online.

## Specific Warranty Coverage

Warranty coverage is specific to the following UVMAX® products: Models PUV-Basic, PUV-8 and PUV-16. Warranty coverage is subject to the conditions and limitations outlined under the heading "General Conditions and Limitations" below.

### Ten-Year Limited Warranty for UV Chamber

VIQUA warrants the UV chamber on the UVMAX® product to be free from defects in material and workmanship for a period of ten (10) years from the date of purchase. During this time, VIQUA will repair or replace, at its option, any defective UVMAX® UV chamber. Please return the defective part to your dealer who will process your claim.

### Three-Year Limited Warranty for Electrical and Hardware Components

VIQUA warrants the electrical (power supply) and hardware components to be free from defects in material and workmanship for a period of three (3) years from the date of purchase. During this time, VIQUA will repair or replace, at its option, any defective parts covered by the warranty. Please return the defective part to your dealer who will process your claim.

### One-Year Limited Warranty for Lamps, Sleeves and UV Sensors

VIQUA warrants lamps, sleeves and UV sensors to be free from defects in material and workmanship for a period of one (1) year from the date of purchase. During this time, VIQUA will repair or replace, at its option, any defective parts covered by the warranty. Your dealer will process your claim and advise whether the defective item needs to be returned for failure analysis.

**IMPORTANT NOTE: Use only genuine UVMAX® replacement lamps and sleeves in your system. Failure to do so may seriously compromise disinfection performance and affect warranty coverage.**

## General Conditions and Limitations

None of the above warranties cover damage caused by improper use or maintenance, accidents, acts of God or minor scratches or imperfections that do not materially impair the operation of the product. The warranties do not cover products that are not installed as outlined in the applicable Owner's Manual.

Parts repaired or replaced under these warranties will be covered under warranty up to the end of the warranty period applicable to the original part. The above warranties do not include the cost of shipping and handling of returned items.

The limited warranties described above are the only warranties applicable to the UVMAX® products listed in the "Specific Warranty Coverage" section. These limited warranties outline the exclusive remedy for all claims based on a failure of or defect in any of these products, whether the claim is based on contract, tort (including negligence), strict liability or otherwise. These warranties are in lieu of all other warranties whether written, oral, implied or statutory. Without limitation, no warranty of merchantability or of fitness for a particular purpose shall apply to any of these products.

VIQUA does not assume any liability for personal injury or property damage caused by the use or misuse of any of the above products. VIQUA shall not in any event be liable for special, incidental, indirect or consequential damages. VIQUA's liability shall, in all instances, be limited to repair or replacement of the defective product or part and this liability will terminate upon expiration of the applicable warranty period.





**VIQUA**<sup>TM</sup>

A TROJAN TECHNOLOGIES BUSINESS

System Tested and Certified by  
NSF International against CSA  
B483.1 and NSF/ANSI 55 for  
Disinfection Performance, Class B